



Operation Manual

## **Junibox Automated Disc Duplicator**

Model #: JB7210 Series (Standalone)

Serial Number: \_\_\_\_\_

(The serial number is labeled on the rear panel of the device.)

---

## PREFACE

### Important Safety Instructions

For your safety, basic precautions should always be followed to reduce risk of damage, electric shock, fire, and personal injury. This includes the following:

- Read this manual carefully and follow all warnings and instructions.
- Operate the unit with only the proper electrical specifications as labeled on the device. Use only 3-wire extension cords that have 3-prong grounding plugs and 3-pole grounding receptacles that accept your device's plug. Make sure the device is connected to a known ground.
- Do not expose this unit to direct sunlight, rain, moisture, water, flammable material, gas, dust, dirt, smoke, pollution or abrupt humidity changes.
- Place this device on a steady level surface in an air-conditioned environment with sufficient ventilation. Do not move this device while the power is on. Handle with care.
- This device generates heat during the duplication process. Out-of-specification or unstable power supply may cause overheating, low productivity, increased failure rate, and damage to the device.
- Use a reliable power source with correct voltage and ample current supply. Give this device a dedicated power outlet. Do not share the outlet with other devices.
- Please make it a habit to always unplug the power cord before troubleshooting or performing maintenance. Always turn the power switch to the Off position when connecting the power cord.
- Do not attempt to disassemble this device or touch any of the moving parts. Refer servicing to qualified service personnel. Unauthorized disassembly or repair will void all warranty.

### Acknowledgments

© 2008, Datatronics Technology Inc. All rights reserved.

**Notices:** Reproduction, adaptation, or translation without prior written permission is prohibited.

**Trademarks:** Datatronics, JuniBox, GetTray, BoxWriter, MiniCubis, and Pronto are the trademarks of Datatronics Technology Inc. All

other products, brands, and trademarks are the property of their respective owners.

**FCC Compliance:** This equipment has been tested and found to comply with the limits for a Class A digital device, pursuant to Part 15 of the FCC Rules. In a domestic environment this product may cause radio interference, in which case the user may be required to take adequate measures.

This equipment generates, uses, and can radiate radio frequency energy and, if not installed and used in accordance with the instructions, may cause harmful interference to radio communications. However, there is no guarantee that interference will not occur in a particular installation. If this equipment does cause harmful interference to radio or television reception, which can be determined by turning the equipment off and on, the user is encouraged to try to correct the interference by one or more of the following measures:

- Reorient or relocate the receiving antenna.
- Increase the separation between the equipment and receiver.
- Connect the equipment to an outlet on a circuit different from that to which the receiver is connected.
- Consult the dealer or an experienced radio/TV technician.

Use of shielded cables is required to comply with the Class A limits of Part 15 of the FCC Rules. You are cautioned that any changes or modifications not expressly approved in this manual could void your authority to operate and/or obtain warranty service for this equipment.

**Limited Warranty (North America):** The information contained in this document is subject to change without notice. Datatronics Technology Inc. makes no warranty of any kind with respect to this information.

Datatronics Technology Inc. guarantees this device for a period of one year from the date of delivery, free from defects in material and workmanship. In case of malfunction or fault, Datatronics Technology Inc. will, at its option, repair or replace the product.

You must return the defective product, protected in the original packaging, with a valid RMA number, to an authorized dealer or reseller within the warranty period accompanied with the proof of purchase.

This warranty only covers parts made by Datatronics Technology Inc. For parts made by other manufacturers, such as hard disks, and disc

recorders, the original manufacturer's warranty applies.

This warranty will not cover abuse, misuse, alteration, modification, tampering, negligence, faulty installation, accidents, lack of reasonable care, unauthorized repairs or service, or if installed to any device not provided with the product, or if the serial number label provided with this product has been broken or removed.

This warranty does not cover damages that occur in shipment, due to acts of God. All repairs and replacement services shall only be handled by Datatronics Technology Inc, and by authorized service centers. Parts used for replacement are covered only for the remainder of the warranty period.

Datatronics Technology Inc. disclaims all implied warranties on this product, including without limitation warranties of merchantability, performance, and fitness for a particular purpose.

In no event will Datatronics Technology Inc. be liable for direct, indirect, special, incidental, tort, economic, contingent or consequential damages resulting from any defect in this product or its documentation, including, without, limitation, damages or costs relating to the loss of data, profits, business or goodwill, even if Datatronics Technology Inc., its authorized dealers or resellers have advertised the possibilities of such damages. In no case shall Datatronics Technology Inc.'s liability exceed the amount paid by the user of this product out of which such claim arose.

Any written or oral information or advice given by the dealer, reseller, agent, sales representative, or employee of Datatronics Technology Inc. will in no way increase the scope of this warranty nor should you rely on such oral or written communication.

**Technical Support:** For technical support and assistance, please contact your local dealer.

For additional information regarding optical disc duplication, printing, and management please visit our website. We value your comments and suggestions and thank you for your purchase.

Datatronics Technology, Inc.  
<http://www.datatronics.com.tw>

## **Table of Contents**

<b>Preface</b>	<b>2</b>
<b>Specifications</b>	<b>6</b>
<b>Unpacking Your JuniBox</b>	<b>7</b>
Package Contents.....	7
<b>Getting Familiar with JuniBox</b>	<b>9</b>
Block Diagram.....	9
A Look at JuniBox .....	9
Rear View.....	10
Control Panel .....	10
LED Indicators .....	11
<b>Device Installation</b>	<b>13</b>
Finding a Place for JuniBox .....	13
Using the Detachable Legs.....	13
JuniBox Installation .....	13
<b>Before Getting Started</b>	<b>15</b>
Tips for Handling Optical Discs.....	15
What You Need to Start a Disc Duplication Session.....	15
Important Tips for Loading Discs to JuniBox .....	15
Rejected Discs .....	15
More Than 30 Discs in One Session .....	16
Automated Multiple-Master-Disc Duplication.....	16
Write Speed: Production Rate vs. Duplication Quality.....	17
Duplicate Disc Verification .....	17
Handling Disc Write Failures.....	18
Turning JuniBox On .....	18
Turning JuniBox Off .....	18
<b>Operation Quick Guide</b>	<b>20</b>
Abort a Running Operation .....	20
Start a Duplication Session.....	20
Duplication Simulation .....	21
Erase a Stack of Rewritable Discs .....	21
Verify a Stack of Discs .....	22
<b>Appendix</b>	<b>23</b>
JuniBox Maintenance.....	23
Choosing Reliable Blank Discs.....	23
Disc Separation.....	23
The Quality of the Master Disc Counts .....	24
Writing Speed.....	24
<b>Frequently Asked Questions</b>	<b>25</b>

---

**SPECIFICATIONS**

---

Disc Recorder	One CD/DVD recorder (JB7210); One Blu-ray/CD/DVD recorder (JB7210-BR)
Input Capacity:	30 discs; 100 discs or more using extension rods (increased capacity using non-stop refill)
Output Capacity:	Dependent capacity (completed discs are placed in front of the unit, in a separate container, or Disc Storage Bin)
Reject Disc Capacity:	3 discs without legs; 30 discs using legs
Write Speed:	CD-R: 40X; CD-RW: 32X; DVD±R: 18X; DVD±R Dual: 10X; DVD-RW: 6X; DVD+RW: 8X Blu-ray: 4X (JB7210-BR)
Operation Method:	Standalone; PC connection is not required
Control Panel:	High-Speed, Safe-Speed, Function, Test/Abort; with corresponding LED Indicators
Disc Size:	120 mm in diameter
Operation Temperature:	42°F to 86°F (6°C to 30°C)
Humidity:	5% to 85%, no condensation
Certification:	CE and FCC; power adaptor is UL approved
Dimensions:	7-3/4" x 8-1/2" x 15-3/8"; 19.5 x 21.3 x 39 cm
Weight:	2.7 kg; 6 lbs (varies upon configuration)
Power:	100 to 240VAC; 50 or 60 Hz

\*Specifications are subject to change without notice.

---

## UNPACKING YOUR JUNIBOX

---

Congratulations on purchasing the JuniBox JB7210 (Standalone) Automated Disc Duplicator. JuniBox is a state-of-the-art, automated, optical disc duplicator, which does not require a PC connection to operate. It is an integrated system with a built-in single optical disc recorder, a hard disk and autoloaders. The embedded controller and built-in hard disk provide an extremely reliable automated, standalone, duplication solution.

JuniBox has a 30 disc capacity, which can be increased to 100 or more using storage extensions, and an enclosure that protects discs from dust. It can also detect faulty discs and separate them from a duplication session. Depending on the configuration of your device during purchase, it may come with a CD/DVD or Blu-ray recorder (JB7210-BR).

Getting JuniBox up and running is simple. The control panel with LED indicators and operation buttons takes minutes to learn. Simply connect the power cord, turn the power switch to the On position, load the master and blank discs into the disc loader, and press the desired duplication speed button.

Please read this manual carefully before using JuniBox. This user guide contains all the information on its operation and maintenance. For additional information regarding optical disc duplication, printing, and management please visit our website. We value your comments and suggestions and thank you for your purchase.

### **Package Contents**

Before opening the package, carefully inspect for any damage. If there is any sign of damage, contact the shipping company and your local dealer immediately.

Save the packing materials in case you need to ship or return your product. The original packaging will ensure the product is protected during transportation. Returning goods without the original packaging may not protect the product during transportation, and will void your warranty.

Once you have removed all the parts included with your package, please check to see if any pieces are missing or damaged. If any part is missing or damaged, contact your local dealer immediately.

The items listed below should be included in the package:

- One JuniBox JB7210 Automated Disc Duplicator
- One power cord
- One power adapter
- One spindle box (serves as the Finish Disc Bin)
- Three Extension Rods (attached to the underside of JuniBox's lid)
- One Alignment Pad
- Four Legs
- One operation manual



## GETTING FAMILIAR WITH JUNIBOX

### Block Diagram

JuniBox JB7210 is an integrated system with a single optical disc drive, hard disk and autoloader. See the illustration below.

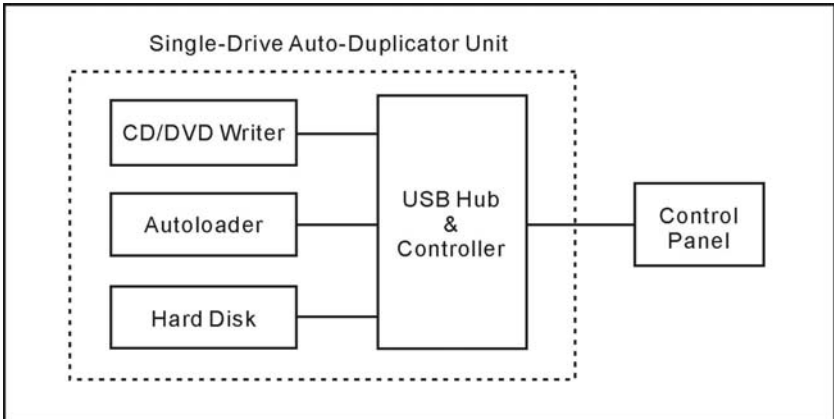

Depending on the configuration of your purchase, your JuniBox may come with one of the following optical disc recorders:

- JuniBox JB7210: CD/DVD recorder
- JuniBox JB7210-BR: Blu-ray/CD/DVD recorder

### A Look at JuniBox

The figure to the right shows JuniBox with a spindle box in front of it to collect and stack finished discs.

- **Lid (Blank Disc Storage)**  
Open the lid to access the blank disc storage area.
- **Control Panel**  
Located on the top front of JuniBox, the control panel

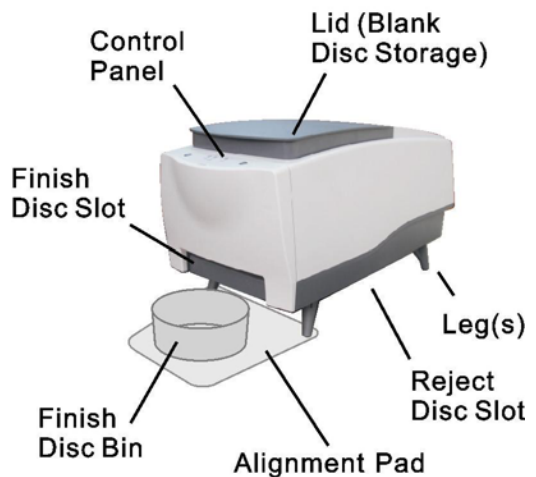

contains the LED indicators and operation buttons.

- **Legs**

Use the four legs included with your JuniBox to provide space underneath for rejected discs.

- **Reject Disc Slot**

The rejected discs will slide out from the Reject Disc Slot at the bottom of the unit. Always allow space beneath JuniBox to accommodate rejected discs.

- **Finish Disc Slot**

Finished discs will exit from this slot.

- **Finish Disc Bin**

This bin serves as the storage container for receiving and stacking completed discs. As illustrated, a spindle box serves as a good Finish Disc Bin.

- **Alignment Pad**

Use the pad to appropriately position the Finish Disc Bin under the Finish Disc Slot.

**Rear View**

- **Power Socket**

Use the provided power cord to connect JuniBox to a wall outlet.

- **Power Switch**

Turn JuniBox on and off.

- **Ventilation**

This allows heat to escape. Do not block this otherwise the unit may overheat.

- **Kensington Security Slot**

Security lock anti-theft system.

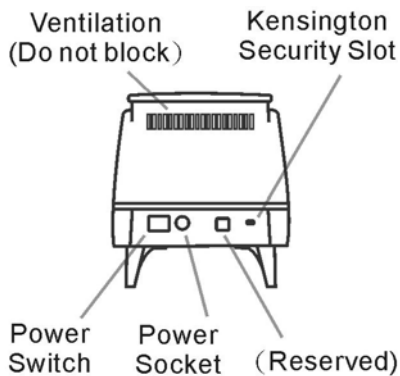

**Control Panel**

There are operation buttons and LED indicators on JuniBox's control panel as illustrated to the right.

- **High-Speed Duplication**

Press to start the duplication

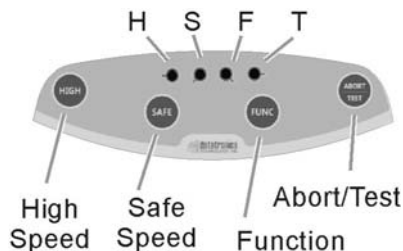

process at the highest possible write speed to produce discs at the maximum production rate.

- **Safe-Speed Duplication**  
Press to start normal speed duplication. This increases quality but decreases output rate. Recommended for audio and video discs.
- **Function Key**  
Press this button to activate or deactivate disc verification during the duplication process.
- **Test/Abort**  
Press to abort the current duplication process or to start a duplication simulation.

***Important:***

The High-Speed Duplication mode will use the maximum recorder speed but may be limited by the write speed of the disc.

**LED Indicators**

JuniBox's status is reflected by the LED indicators. When turned on, it will enter initialization indicated by a flashing green ready light. When initialization is complete, the ready light will change to steady green. The table below describes the meanings of the LED indicators.

H	S	F	T	Description
●	●	●	●	The power switch is in the Off position
⇒	⇒	⇒	⇒	Device Initialization
●	●	●	○	Ready Mode
◎	●	●	○	High-Speed Duplication
●	◎	●	○	Safe-Speed Duplication
◎	●	○	○	High-Speed Duplication with Disc Verification
●	◎	○	○	Safe-Speed Duplication with Disc Verification
●	●	◎	○	Disc Verification in progress
⇒	⇒	⇒	○	Erasing rewritable disc
●	●	●	◎	Error Encountered
●	●	○	●	Function Key Enabled

○: Lit

●: Off

◎: Flash

⇒: Running

(This page is intentionally left blank.)

## DEVICE INSTALLATION

### Finding a Place for JuniBox

JuniBox should be placed on a fairly level surface, firm enough to support the unit and discs. Always allow ample workspace for your operation, with easy access to the blank and finished discs.

Do not expose the unit to direct sunlight or high humidity, as it may cause the unit to malfunction.

If you desire, JuniBox can be placed on a raised block so there is ample room to receive discs from the Finish Disc Slot. Please refer to the “More Than 30 Discs in One Session” section for details.

### Using the Detachable Legs

JuniBox is designed to work either with or without detachable legs. Without the legs, the Reject Disc Slot (recession) on JuniBox's base will hold up to 3 rejected discs.

If your application doesn't involve rejected discs or separating a group of discs from others, you may use JuniBox without the legs. It is, however, recommended to use the legs when possible.

The legs will raise JuniBox providing sufficient room to accommodate additional rejected discs, as well as easier access to them beneath the unit.

Attaching legs to JuniBox is simple. Inserting one leg after another on JuniBox's base, match the leg to JuniBox (A to A') and gently snap the leg into the receptacle (B to B') until it is firmly attached.

To remove the legs, gently press the notch (N) and pull it outward from the receptacle (B').

### JuniBox Installation

Follow the steps below to complete JuniBox's hardware installation:

- 1) Place JuniBox on level surface so that it stands firmly on its legs.
- 2) Place the spindle box that came with the unit in front of JuniBox.

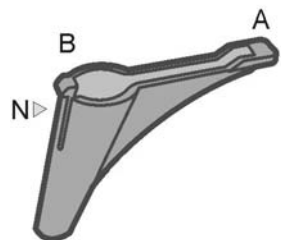
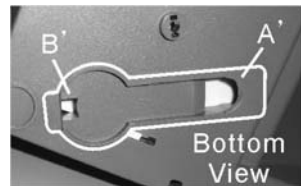

Use the alignment pad to appropriately position the spindle box under the Finish Disc Slot.

- 3) Use the power cord that came with the unit to connect JuniBox to a wall outlet with a reliable power supply.

You have now successfully completed the installation of JuniBox device.

## BEFORE GETTING STARTED

### Tips for Handling Optical Discs

Never touch the printable or data surface of the disc, as it may decrease quality and disc lifespan. Refer to the arrows on the illustration to the right, Always handle discs from the outer edge or the center hole.

### What You Need to Start a Disc Duplication Session

The JuniBox JB7210 is a standalone duplicator, which does not require a computer connection. You will need the following to start a duplication session:

- **Master Discs**  
The original disc providing the source of data for a duplication session.
- **Blank Discs**  
The disc that JuniBox will write the source data to during a duplication session.

### Important Tips for Loading Discs to JuniBox

When the disc loader is empty, do not attempt to load many discs at once.

First, carefully load only one disc into the disc loader and assure it is firmly resting on the three wheels seen in the illustration to the right. You may then gradually load additional discs on top of the first disc, until the loader is full.

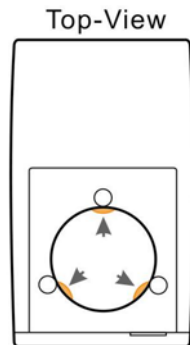

JuniBox processes discs in a First In, First Out (FIFO) sequence. During a duplication session, if a disc refill is required, before the loader becomes empty, gently load additional discs.

### Rejected Discs

JuniBox is designed to have Rejected Discs come out underneath the unit. Do not block the Reject Disc Slot.

Periodically remove rejected discs so that there is room to accommodate more discs or raise JuniBox using the provided legs to

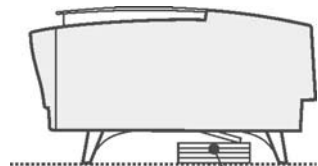

Rejected discs come out beneath the unit

increase space underneath for more discs.

**Important:**

JuniBox will stop operation if a rejected disc cannot clear the Reject Disc Slot.

**More Than 30 Discs in One Session**

Using the extension rods, JuniBox can process 100 or more discs without refilling. To increase JuniBox's capacity to 100 discs, please follow the instructions below:

- 1) Open the Blank Disc Storage Lid.
- 2) Remove the extension rods from the lid's underside.
- 3) One after another align the rods into the three holes on the disc loader, then, gently turn the rods counterclockwise to make sure they are firmly attached;
- 4) Use a suitable box to raise JuniBox approximately 96 mm high to account for the output of 100 or more discs.
- 5) Use the alignment pad to appropriately position the Finish Disc Bin below the Finish Disc Slot. The Finish Disc Bin may be a spindle box or a container with enough depth to accommodate 100 or more discs in a session.

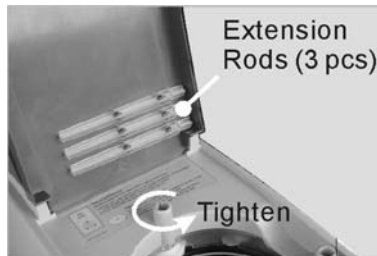
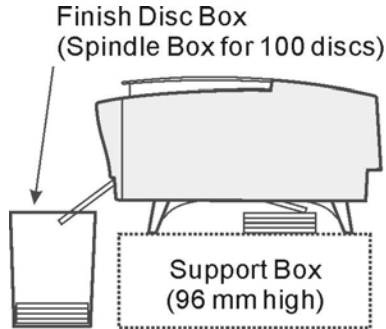

Since JuniBox is equipped with a FIFO (First-In-First-Out) disc loader, you may simply refill discs before the disc loader becomes empty. This will allow an unlimited number of additional discs to be processed in one session, as long as the Finish Disc Bin is continually emptied.

To remove the extension rods from the disc loader, turn the rods clockwise and pull them upward vertically. When not using the rods, return them to their original position on the lid's underside.

**Automated Multiple-Master-Disc Duplication**

JuniBox not only performs one-to-multiple, but also multiple-to-multiple



disc duplication. Whenever JuniBox detects a non-blank disc in a recorder, a disc image will be written to the built-in hard disk. The disc image is then used to duplicate all the following blank discs, until another master disc is detected or the loader becomes empty.

When another non-blank disc is detected, a new disc image will be written to the built-in hard disk. The previously stored image will be overwritten and the new image will be used for disc duplication.

Do not use rewritable discs as a master disc, since JuniBox is designed to always erase rewritable discs before attempting to write data to them.

### **Write Speed: Production Rate vs. Duplication Quality**

By pressing the appropriate button, JuniBox can perform High-Speed and Safe-Speed Duplication accordingly. High-Speed Duplication writes to discs at the highest possible speed according to the recorder and blank disc characteristics.

Although High-Speed Duplication takes less time to write to a disc, and produces more discs per hour than Safe-Speed Duplication, a higher failure rate may be encountered, especially when the blank disc quality is not good.

Most users choose High-Speed Duplication, while professional users prefer Safe-Speed to duplicate audio and video discs, for improved duplicate disc quality.

When duplicate disc quality is critical, activate the Verify Disc mode to have JuniBox read and verify each duplicate disc with the source image immediately after the disc is duplicated.

### **Duplicate Disc Verification**

JuniBox is not only able to verify each duplicate disc with the source disc image during a duplication cycle, it can batch verify a stack of discs with a master disc. Duplicate disc verification involves reading and comparing the duplicate disc image with the master disc image on the hard disk.

Disc verification is performed according to the disc data format. For data disc verification, both the read and comparison process will be performed. However, due to the limitation of industry standards, for audio disc verification it will only perform the reading check, and not the comparison process.

## Handling Disc Write Failures

Some discs may be defective and fail during a write session. A failed disc will be sent to the Reject Disc Slot.

To avoid excessive disc failure, JuniBox is designed with the following rules when disc failure is encountered:

- In a normal duplication session if the recorder continuously fails to write to ten discs in sequence, this recorder will be deactivated.
- JuniBox will halt the active duplication session and the LED indicator status will show an error.

To resume operation from an error, carefully check for and resolve any noticeable problems, press the button for the desired duplication speed to resume the session.

### ***Important:***

In case JuniBox has been turned off, always wait for 30 seconds before turning it back on. Then, reload the master and blank discs and press the appropriate button to start a new job.

## Turning JuniBox On

Follow the steps below to get your JuniBox ready:

- 1) Connect the power cord to JuniBox and a wall outlet.
- 2) Turn JuniBox's power switch to the On position.

JuniBox will enter the initialization process and will remove any discs inside the optical recorder. Be patient until the initialization process has completed.

When initialization is complete, you will see the "ready" indicator light up signaling that JuniBox is ready for a disc operation

## Turning JuniBox Off

To turn JuniBox off, turn the power switch to the Off position. In case there is a duplication session underway, abort or wait until it has completed.

Although it is fine to leave the power cord plugged in, it is recommended that you unplug the cord for increased safety when JuniBox is not used for extended periods of time.

(This page is intentionally left blank.)

## OPERATION QUICK GUIDE

### Abort a Running Operation

To abort a duplication session, press the Test/Abort button. If the recorder is currently writing to disc, JuniBox is designed to abort the duplication session after the recorder has completed writing to disc.



Test/Abort

**Important:**

Turning the power switch to the Off position will immediately terminate the active duplication session, damaging any disc in the process of being written to. Only turn off the power in case of emergency.

### Start a Duplication Session

High-Speed Duplication produces more discs per hour, yet Safe-Speed better assures duplicate disc quality especially for audio and video discs.

Follow the steps below to start a one-to-multiple disc duplication session:

- 1) Load the master disc into the disc loader.
- 2) Load the desired quantity of blank discs on top of the master into the disc loader.
- 3) Press either the High or Safe-Speed Duplication button to start. JuniBox will run the operation until the disc loader is empty.



High Speed Duplication



Safe Speed Duplication

**Important:**

In duplication mode whenever a rewritable disc is detected, JuniBox is designed to always erase the disc. Do not use rewritable discs as master discs because the data on the disc will be erased.



**Important:**

To verify your written data, press the Function Key which will light up its LED



and then press the High or Safe-Speed Duplication button to start.

If using multiple master discs to produce different quantities of duplicate discs, repeat steps 1 and 2 to load additional sets of masters and blank discs. Then, press the High or Safe-Speed Duplication button to start duplicating discs. The illustration below shows an example of three disc sets, stacked in interleave mode with one on top of another, for multiple-to-multiple duplication,

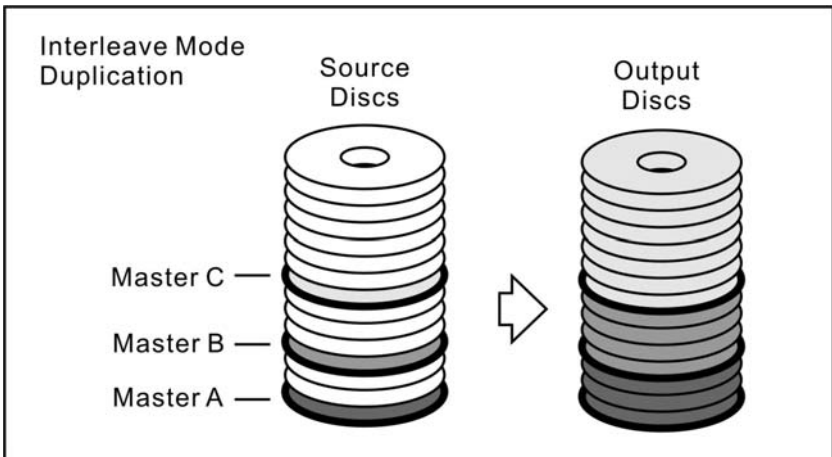

### Duplication Simulation

This mode is used to test discs for writing by emulating a duplication session and will not actually write to the discs. Follow the steps below to start a duplication simulation session:

- 1) Load the master disc into the disc loader.
- 2) Load the desired quantity of blank discs on top of the master disc.
- 3) Press the Test/Abort button to start. JuniBox will run the operation until the disc loader is empty.



#### **Important:**

Duplication simulation will not work with DVD+R, DVD+RW and DVD+R DL discs. When a DVD+ disc is detected it will be rejected.

### Erase a Stack of Rewritable Discs

This operation erases a stack of rewritable discs for



future use:

- 1) Load the rewritable discs you would like to erase into the disc loader.
- 2) Press the Test/Abort button to start. JuniBox will erase discs until the disc loader is empty.

### Verify a Stack of Discs

This operation verifies a stack of duplicate discs against a master disc. Follow the steps below to start the verification process:

- 1) Load the master disc and the discs you would like to verify.
- 2) Press the Function Key which will light up its LED. Press the Test/Abort button to start.



---

## APPENDIX

### JuniBox Maintenance

Periodically cleaning the device will ensure proper performance. Follow the steps below to maintain JuniBox:

- 1) Turn the power switch to the Off position.
- 2) Remove the master and blank discs.
- 3) Unplug the power cord from the wall outlet.
- 4) Clean the JuniBox unit using a lint-free cloth moistened with warm water.
- 5) Dry the unit immediately with a dry lint-free cloth.

### Choosing Reliable Blank Discs

The quality of a recordable disc depends on its chemical and coating technology. There are a variety of discs with various degrees of disc quality available on the market. If you encounter a high failure rate, please try a different type, speed, or brand of disc.

There are many different brands, speeds and CD/DVD recordable media formats on the market. We do our best to test certain media types. It is impossible for us to guarantee that all discs will be compatible.

Please choose a blank disc that is most suitable for your application. You may contact your local dealer for advice on the best suitable blank disc for your system. In addition, we suggest users to test blank discs by using disc simulation before actually writing to discs.

***Important:***

As with blank discs, the quality and the data format of the master disc play a critical role in the duplication process

### Disc Separation

Certain blank discs may tend to stick to each other or may be difficult to separate. Avoid these types of discs. JuniBox is equipped with a patent pending disc separator, which handles discs that adhere to each other better than traditional autoloaders. However, it is strongly recommended that you separate or loosen blank discs from each other before use.

## **The Quality of the Master Disc Counts**

As with blank discs, the quality and the data format of the master disc play a critical role in the duplication process. If you encounter difficulties try Safe-Speed Duplication to increase quality and lower failure rate.

### **Writing Speed**

The recorder will automatically adjust the writing speed according to the disc quality. The system will monitor and automatically adjust the writing speed as the optical laser moves from the inner ring to the outer ring, up to the selected speed. The recorder's maximum speed may never be reached if a lower grade disc is used.

At the maximum speed, for a single recorder, duplicating a 4.7 GB DVD should not take more than 8 minutes. Please check both the quality of the blank and the master disc if the duplication process takes more than 8 minutes for a single disc. Use a reliable master disc for testing purposes. You should also try different specification and brands of blank discs.

You should also check the power supply's voltage and amperes. Insufficient power supply may decrease output rate or increase failure rate.

As a general rule, a lower writing speed will improve quality. When creating audio and video discs a lower writing speed is recommended to assure quality.



---

## FREQUENTLY ASKED QUESTIONS

---

### **Why is my duplication failure rate so high?**

- Try a lower writing speed using Safe-Speed Duplication.
- Use a different brand of blank discs.
- Check the power source.

### **Why do my discs get stuck in the disc loader during the duplication process?**

- Check to see if the disc is the standard size (120mm).
- Make sure discs are level in the loader.
- Reduce the quantity of discs per load. Some discs may bend from the weight of the discs placed on top of them.
- Use a different brand of blank discs.

### **Why won't the power switch work all the time?**

- Allow a 30 second interval when switching the power on and off.

### **Why does the disc loader fail to pick up the disc?**

- Check to see if the disc is the standard size (120mm).
- Make sure the discs are not bent or damaged.

### **Why is the disc unloader dropping two or more discs at a time?**

- Check to see if the disc is the standard size (120mm).
- Make sure the discs are level when inserted.
- Separate or loosen the discs from each other before use.
- Use the same brand of discs. Do not mix disc types or brands.
- Reduce the quantity of discs per load. Some discs may bend from the weight of the discs placed on top of them.
- Use a different brand of blank discs.

### **How can I restart or reset JuniBox when it is not working properly?**

- Turn the power switch to the Off position and back to the On position after waiting 30 seconds. If this does not solve the problem, please contact your dealer or authorized service center.

