

JMVROBOTIQUE

COMPLETE SOLUTIONS FOR ON-DEMAND CD & DVD PRODUCTION



CDC100
CD Jewel Case Wrapper

OPERATING & MAINTENANCE MANUAL

**Thank you for purchasing a JMV Robotique
CDC100 CD Jewel Case Wrapper**

OPERATING & MAINTENANCE MANUAL

Document Reference No. TP 000 170 (Rev 1.02)

Production Standard

T.ZZ 004 010 (220v)

T.ZZ 004 011 (110v)

JMV Robotique

ZI du Clos Aux Pois
6/8 Rue de la Closerie
LISSES
91048 EVRY Cedex
France

Tel: 33 (0) 1 60 86 15 25

Fax: 33 (0) 1 60 86 10 74

Email: contact@jmvrobotique.com

www.jmvrobotique.com



WARNING

To avoid electrical shock hazards, unit covers should only be removed by authorized personnel.



COPYRIGHT

This document is the property of JMV Robotique and it may not be reproduced, copied or exhibited to a third party without the written permission of JMV Robotique.



ENVIRONMENTAL PROTECTION

Waste electrical products should not be thrown away with household waste. Please recycle where facilities exist. Check with your local authority or retailer for recycling advice.

JMV Robotique reserves the right to amend or modify the specifications and design criteria applying to these products.

WARRANTY TERMS

The CDC100 is covered by the JMV Robotique standard warranty.

WARRANTY EXCLUSIONS

We will not provide warranty repairs if, in our opinion, the problem resulted from externally caused damage, use outside the product's specification, faults caused by inexperienced or non-approved repairers.

The warranty does not cover the replacement of used consumables (or of parts which need periodic replacement during the life of the product as a result of the use made of them) unless the consumable itself is defective.

IF YOUR PRODUCT FAILS WITHIN THE WARRANTY PERIOD

- Prepare a description of the problem you have had
- Make sure you have your proof of purchase document (invoice or receipt.)
- Contact your supplier

OPTIONAL EXTENDED WARRANTY PROGRAMMES

Optional extended warranty programs are available. JMV Robotique extended warranty programs can only be purchased at the same time or shortly after the product to be covered has been purchased. Contact JMV Robotique for details.

TABLE OF CONTENTS

Section 1 SPECIFICATION	6
Section 2 INTRODUCTION & INSTALLATION	7
2.1 Introduction	7
2.2 Installation	7
Section 3 ADJUSTMENTS	8
3.1 Adjusting the side heater control	8
3.2 Adjusting the front heater control	8
Section 4 OPERATION	9-12
Section 5 SPARE PARTS LIST	13
Appendix A Diagram 1 Internal Components View	14
Appendix B Diagram 2: Pcb Circuit Diagram	15
Appendix C Diagram 3: Pcb Circuit Diagram	16
Appendix D Diagram 4: Pcb Component layout	17
Standard Terms & Conditions	18-21

SECTION 1: SPECIFICATION

Power supply:	115V 50/60Hz (VS4011) 230V 50/60Hz (VS4010)
Fuse:	1.6 Amp Anti Surge
Hopper capacity:	15 CD jewel cases
Throughput:	300 per hour
Duty Cycle:	Continuous
Dimensions:	Height: 11.5" (292m) Width: 19.25" (489 mm) Depth: 23.0" (580 mm)
Gross Weight:	52.8 lbs (24Kg)

WRAPPING MATERIAL SPECIFICATION

Raw Sheet:	Dimensions	106mm (6.3") x 275mm (10.8")
	Sheet Thickness	32 microns (0.0013")
	Material	Polypropylene

SECTION 2: INTRODUCTION & INSTALLATION

2.1 Introduction

The CDC100 has been specially designed to provide a professional CD Jewel Case wrapping facility. The semi-automatic operation is simple and effective using pre-cut sheets of the polypropylene wrapping material. The first seal is effected manually and the finishing folds and seal are completed automatically. The CDC100 is a tabletop mounted unit, which can easily be transported if required.

2.2 Installation

2.2.1 Unpacking

Your CDC100 has been fully tested at the factory and our Quality Control Department has ensured before despatch that it performs satisfactorily to the full specification

Carefully remove your **CDC100** from its shipping carton and verify that all parts are present. If there are missing or damaged parts contact JMV Robotique or an authorised distributor immediately.

You should find the following:

- CDC100 CD Jewel Case Wrapper
- Power Cable
- Manual



Note:

If your CDC100 is damaged during shipment, please contact the freight carrier first, then, contact your distributor or JMV Robotique. You should save your shipping materials so that if the need arises, you can return your CDC100 for service. This packaging was designed specifically for shipping your CDC100. Other packaging may not be suitable.

After unpacking, place your **CDC100** on a flat and clear surface.

2.2.2 Power Wiring

The **CDC100** will accept power from either 220v 50Hz or 110v 60Hz depending on the model you have ordered. The power connection is made to the **CDC100** via the power cable supplied. The power circuit should be rated in accordance with the national and local electrical codes.



CAUTION:

The machine may be damaged if an incorrect voltage is used. A good electrical ground must be connected to the CDC100.

SECTION 3: ADJUSTMENTS

The CDC100 has been pre-set with temperatures of heaters and cycle times suitable for a typical Jewel Case. Under normal circumstances the temperature settings should not require adjustment, however should difficulty in obtaining a reliable weld be experienced the settings may be adjusted via controls on the front panel. Care should be exercised not to set an excessively high temperature which may result in damaged cases.

3.1 Adjusting the Side Heater Control

The side heater control varies the temperature of the side heaters and should be used in conjunction with the timer control. Clockwise rotation increases the temperature.

3.2 Adjusting the Front Heater Control

The front heater control varies the temperature of the front heater used in the first stage of the wrapping and will determine how long the heater is held manually in contact with the case. Clockwise rotation increases the temperature.



Note:

The efficiency of operation of the CDC100 will obviously be controlled to some degree by the ability and experience of the operator. However it is recommended that the CDC100 be operated on a suitably high surface allowing the operator to judge with some accuracy the positioning of the pre-cut sheets of polypropylene in the unit.

SECTION 4: OPERATION

Wrapping the Jewel Case on the CDC100 is a two-stage operation. The first stage involves sealing two ends of a pre-cut sheet of polypropylene, wrapped around the Jewel Case, together. The final stage folds and seals the edges of the sheet around the case automatically.

1. After connecting to the power supply, power up the **CDC100** using the switch situated on the side of the machine. The commands on the front panel of the machine are as following
 - 1 - "Start/Stop" push button and indicator
 - 2 - "Rest Default" push button and indicator
 - 3 - "Front Heater" potentiometer & indicator
 - 4 - "Side Heater" potentiometer & indicator



Fig. 1

When the machine is switched **ON**, both temperature indicators (3 & 4 above) must be **ON**. If this is not the case not, using a screwdriver, turn the potentiometer clockwise until the light goes **ON**. Wait approximately 15 minutes to let the heaters reach their working temperature.

2. Lift up the hinged lid of the folding tray in front of the control panel and place the polypropylene sheet centrally in the tray with one end of the sheet pushed against the two tabs at the front edge of the tray (figures 2 and 3).



Fig. 2

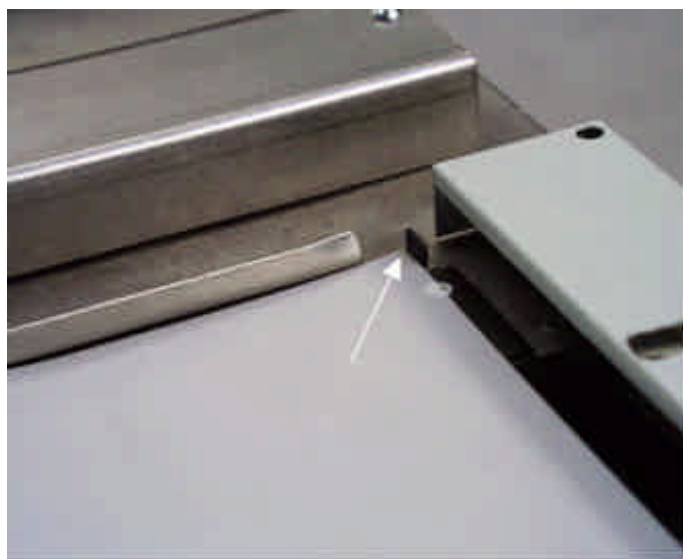

Fig 3

3. Place a Jewel Case in the tray on top of the polypropylene sheet. By positioning the lower front edge of the case against the rear edge of the black guide plate and lowering the rear edge of the case down against the rear guide. The case must be front face 'up' with the hinge on the left-hand side. (figure 4 and 5)

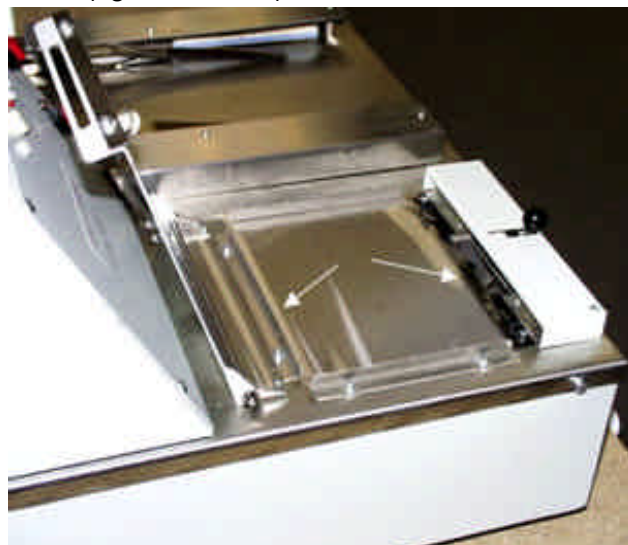

Fig. 4



Fig. 5

4. Fold the remaining half of the polypropylene sheet down over the case and lightly tension the sheet in the forward direction with finger pressure and hold in the sheet in position with thumb pressure then trap the sheet in position with the hinged lid of the tray. A cut-out in the lid is provided to allow thumb pressure to be maintained until the lid is closed. (figure 6)



Fig. 6

5. While holding the tray lid down apply heat to the two ends of the polypropylene sheet by pushing the heater onto the front edge of the case and holding it there for two seconds. The heater position is controlled by pushing the black knob, directly in front of the tray, towards the tray up to a mechanical stop. (figure 7)



Fig. 7

6. Hinge up the tray lid and remove the sleeved Jewel Case. Taking care not to allow the case to slide out of the sleeve rotate the case 180 degrees left to right. I.E., the case hinge on the right-hand side but with the front face down and place it in the hopper. (figure 8)



Fig. 8

7. Repeat the above procedure for at least two more cases which is required to allow the hopper and the second stage of the wrapping to function correctly.
8. Press the start/stop button on the control panel and the cases in the hopper will be pushed forward one at a time between the side folders and heaters and ejected at the front of the unit in a fully wrapped condition.



Note:

If at any time the unit fails to respond to the start/stop button the reset/default button must be pushed to reset the hopper and side heater mechanisms.

SECTION 5: SPARE PARTS

Ref. Diagram 1

Item No.	VSL Part No.	Description	
1	T.JM 000 202	DC Motor 24RPM	1
2	T.JM 000 250	Bearing 604ZZ	4
9	T.JM 000 251	Electro magnet	2
11	T.JM 000 252	Left Side heater	2
11.1	T.JM 000 253	Front heater	1
11.3	T.JM 000 268	Right Side Heater	1
12	T.JM 000 254	Safety block	1
14	T.JM 000 255	Upper right cover	1
14.1	T.JM 000 256	Upper left cover	1
18	T.JM 000 257	Welding finger	1
50	T.JM 000 258	Electronic board	1
51	T.JM 000 259	Transformer 2 x 9v 300 VA	1
53	T.JM 000 267	Main Power Plug	1
54	T.JM 000 091	Fuse 3.15 amp	1
56	T.JM 000 047	Microswitch	3
58	T.JM 000 261	Fan	1
59	T.JM 000 125	24v Power Supply	1
60	T.JM 000 126	12v Power Supply	1
102	T.JM 000 262	Pusher	1
208	T.JM 000 269	Front Cover with Shaft & Conformer	
209	T.JM 000 263	Folder finger	1
210	T.JM 000 264	Fold ramp right	1
210.1	T.JM 000 265	Fold ramp left	1
216	T.JM 000 272	Front Heater Guard	1
F1 & F2	FF 100 009	Fuse 10 amp (control board)	2
F3	FF 100 014	Fuse 3.15 amp (control board)	1

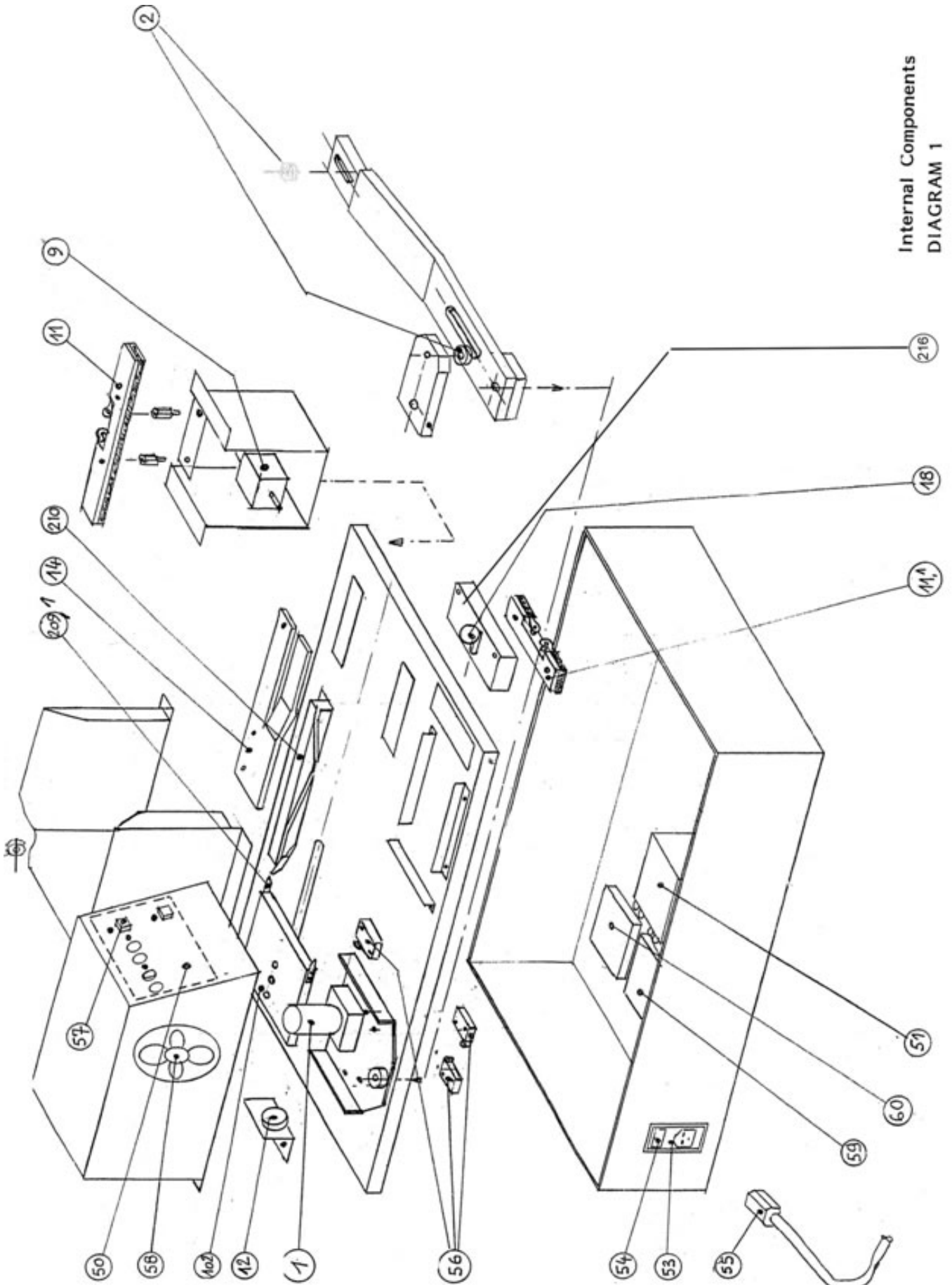

Internal Components
DIAGRAM 1

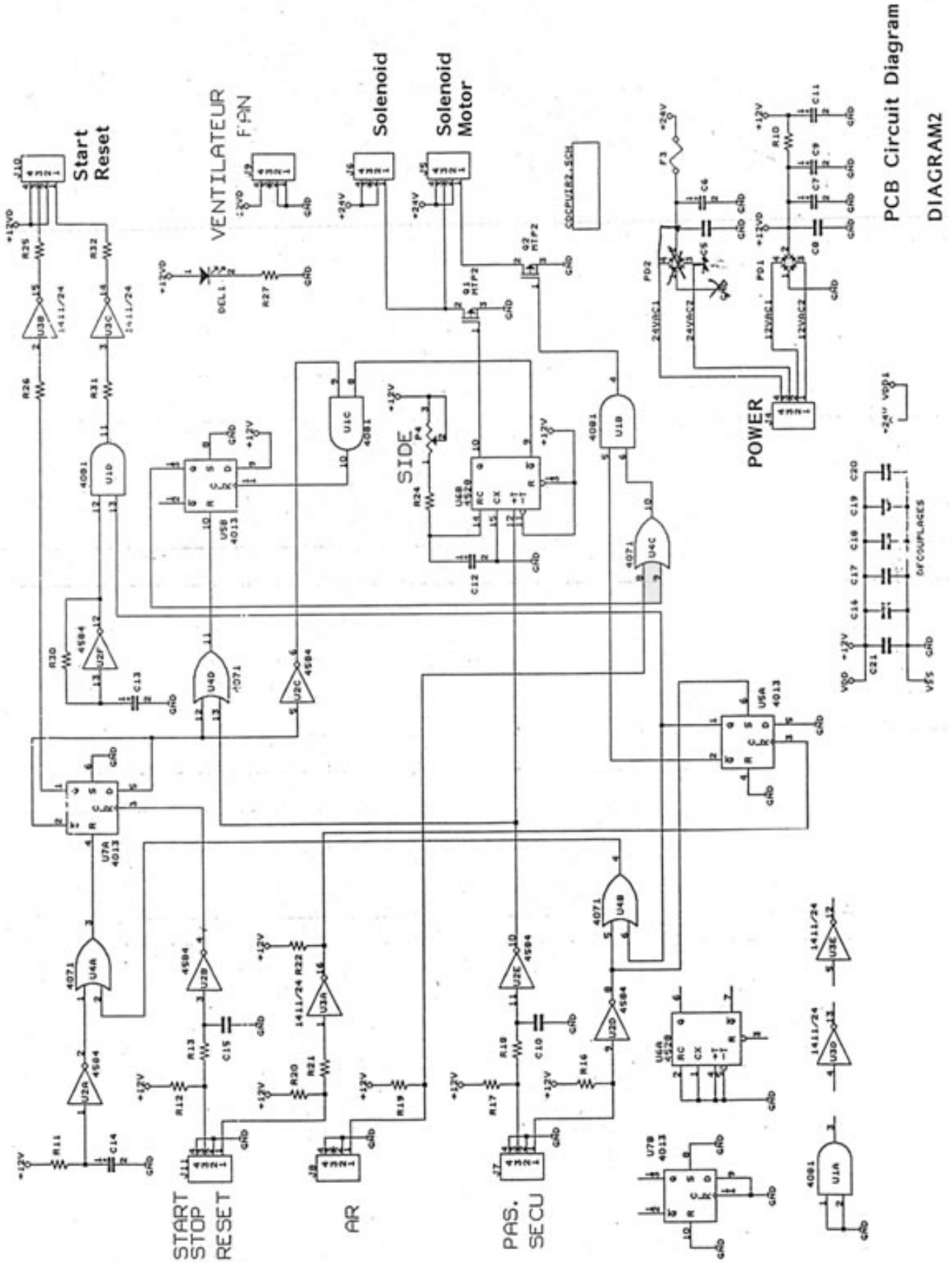

PCB Circuit Diagram
DIAGRAM2

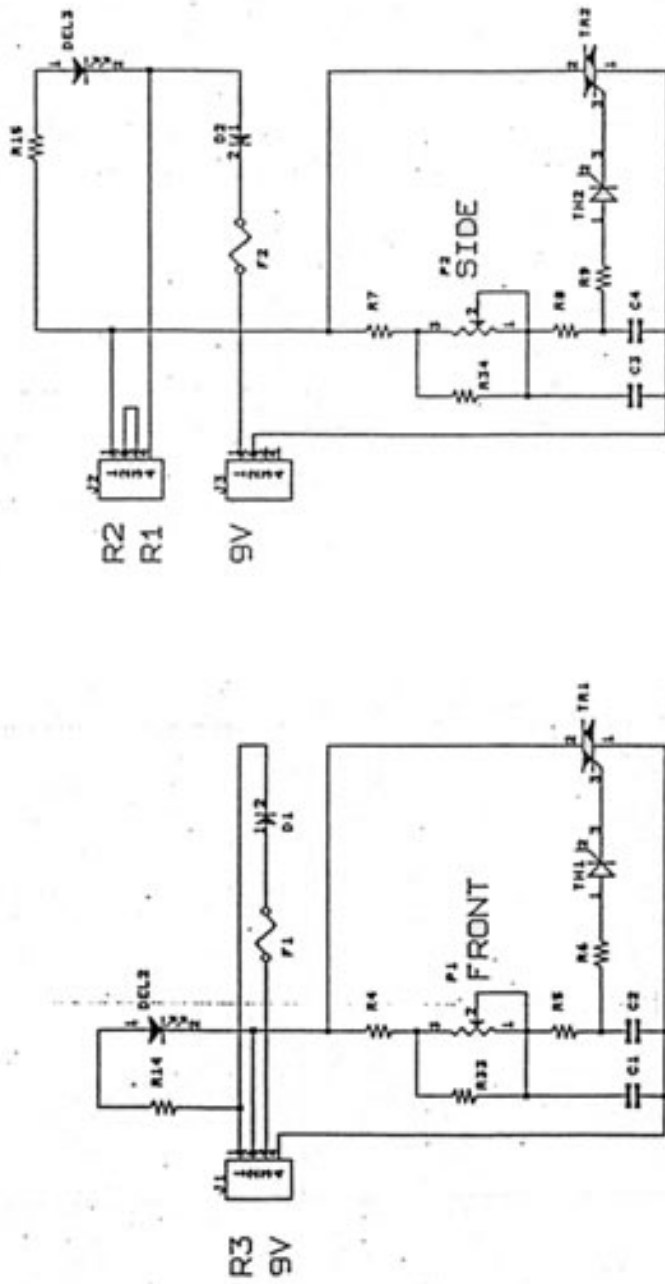

PCB Circuit Diagram

DIAGRAM 3

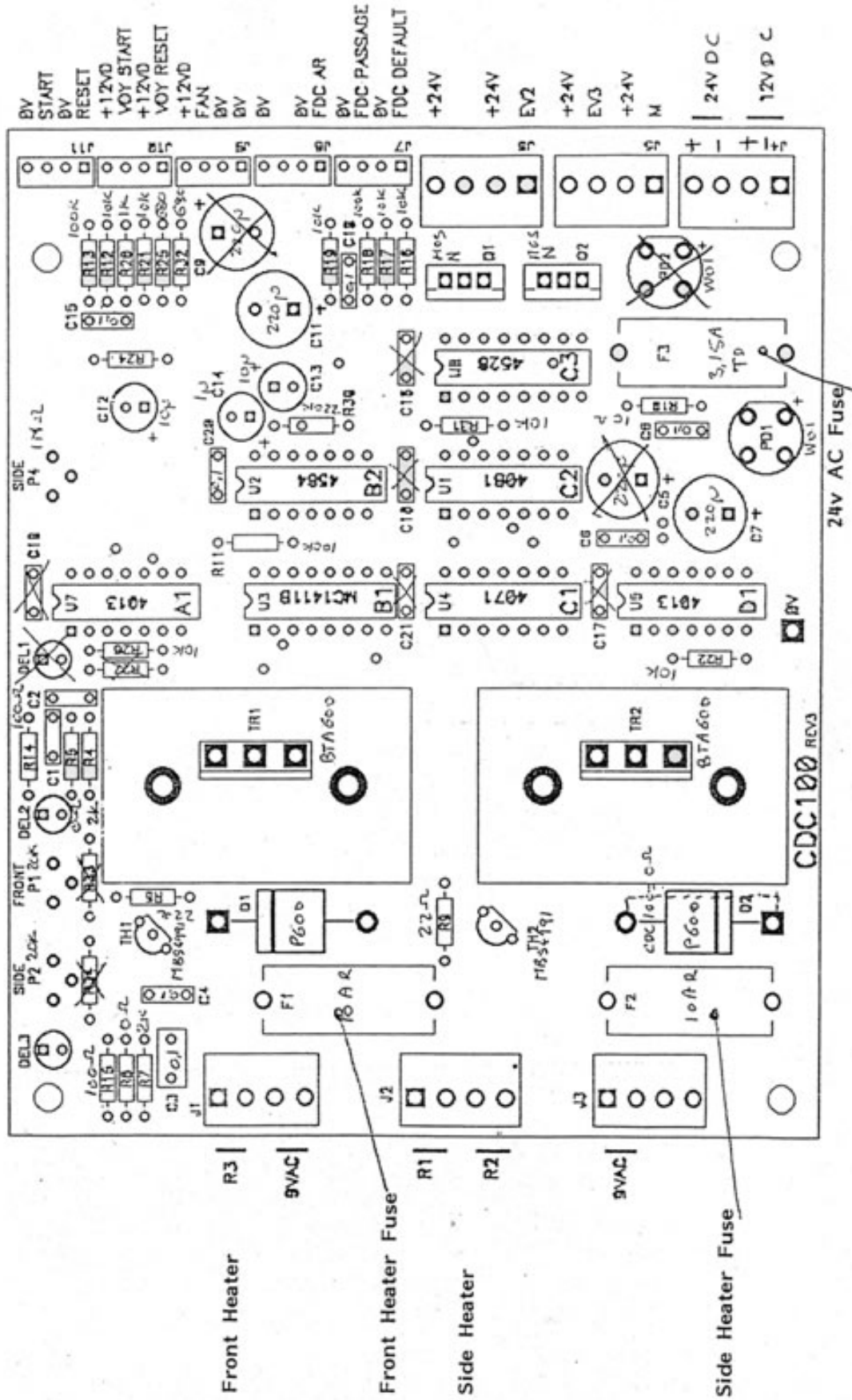

PCB Component Layout
DIAGRAM 4

STANDARD TERMS AND CONDITIONS OF SALE

In these conditions JMV Robotique has its registered office at ZI du Clos Aux Pois, 6/8 Rue de la Closerie, LISSES, 91048 EVRY Cedex, France. And the "Purchaser" is an individual or company with whom JMV Robotique contracts.

All orders are accepted by JMV Robotique subject to Conditions of Sale set out below

1. GENERAL

These conditions shall prevail over any terms or conditions, which the Purchaser may seek or have sought to impose. Any conditions in the Purchaser's Order will be binding only so far as they are compatible with these Terms and Conditions and are expressly accepted by a Director of JMV Robotique in writing.

2. ERRORS

Clerical errors may be corrected by JMV Robotique at any time.

3. PRICES

The prices quoted are Ex Works and exclude Value Added Tax/sales tax. Any published list price shall be subject to revision without notice according to JMV Robotique prices ruling at the time of delivery.

4. SETTLEMENT TERMS

Punctual payment is the essence of the Contract and the Purchaser will pay interest at the rate of 2% per month or part thereof of any overdue payments. Provided that the Purchaser has produced references which are in JMV Robotique' opinion are satisfactory Settlement Terms will be net 30 days from delivery. In all other cases payment shall be in advance upon submission by JMV Robotique of a pro forma invoice.

5. DELIVERY

All times quoted for delivery are from receipt from the purchaser of a written order to proceed. Unless otherwise agreed in writing any quoted delivery date shall only be an estimate thereof and shall not be essence of the Contract. Whilst all reasonable endeavours will be made to comply with estimated delivery dates JMV Robotique does not accept any liability in respect of failure or delay in delivery. Where a Purchaser's Order calls for a number of items JMV Robotique reserves the right to deliver all or any as soon as they are available at JMV Robotique' premises and the Purchaser shall honour all statements presented in respect of such deliveries in accordance with the Settlement Terms. Notification to the Purchaser by JMV Robotique that the goods are available for delivery to an independent carrier or to the Purchaser or his agent shall constitute delivery to the Purchaser. In all cases the carrier acts as Agent of the Purchaser.

6. EXPORT CONTROL

If the goods or components thereof are licensed by the US Government for ultimate destination within the United Kingdom and any other EEC Country then the goods may not be re-exported without the approval of JMV Robotique in writing.

7. INSPECTION AND ACCEPTANCE

THE PURCHASER MUST INSPECT THE PRODUCTS as soon as is reasonably practicable after delivery and shall within 3 working days of delivery give notice to JMV Robotique in detail of any defect in the Products or of any other complaint which the Purchaser may have in relation to the Products. Upon acceptance of the goods the Purchaser shall be deemed to acknowledge that the goods so accepted conform in all respects with the specification of the goods ordered. If the Purchaser desires to inspect the goods prior to delivery such inspection must be made at JMV Robotique' premises and notification of this requirement must be given in writing at the time of placing the order. If upon inspection the goods are approved by or on behalf of the Purchaser such approval shall constitute acceptance of the goods If no such inspection is made the Purchaser shall be deemed to have accepted the goods when they are delivered to him or his agent or carrier unless the Purchaser gives written notice to the contrary to JMV Robotique within three working days of delivery. If the Purchaser fails to give such notice, the Products shall be conclusively presumed to be in all respects in accordance with the contract and free from any defect which would be apparent on reasonable examination and the Purchaser shall be deemed to have accepted the Products

accordingly. The Purchaser acknowledges that JMV Robotique does not write software comprised in Products sold by it and, accordingly, the Purchaser acknowledges that it is its sole responsibility to check (by the application of appropriate diagnostic software) for the presence of computer viruses in software comprised in Products before such Products are used or disposed of. In the event that the Purchaser establishes to JMV Robotique' reasonable satisfaction that the Products are not in accordance with the contract or are so defective, the Purchaser's sole remedy in respect of such non-accordance or defects shall be limited as JMV Robotique may elect to the replacement of the Products or refund of the purchase price or, where sums are owed by the Purchaser to JMV Robotique, the issue of a credit note against the return of the Products.

THE PURCHASER MUST REFUSE PARCELS DELIVERED TO HIM IN A DAMAGED CONDITION.

In no circumstances shall JMV Robotique be liable to compensate the Purchaser in damages or otherwise for non-delivery or late delivery of the Products or for any loss consequential or otherwise arising from non-delivery or late delivery.

8. CANCELLATION OF ORDER

If at any time the Purchaser cancels an order for goods or services which JMV Robotique specifies to be "non-standard", i.e. not detailed on the current price list, JMV Robotique shall be entitled to claim as damages an amount equal to 75% of the value of the order. For standard goods or services damages would equate to 50% of the value of the order. These amounts the Purchaser agrees represents a genuine pre-estimate of JMV Robotique' loss. Upon the cancellation of any order, JMV Robotique shall have the right to realize at its discretion after 60 days all monies, securities or goods pledged with or held by it on behalf of the Purchaser and to apply the proceeds in or towards the satisfaction of such claim for damages and the Purchaser shall have no claim whatsoever against JMV Robotique in connection therewith.

9. PASSING OF PROPERTY AND RISK

The goods shall remain the sole and absolute property of JMV Robotique as legal and equitable owner until such times as the Purchaser shall have paid to JMV Robotique the agreed price. From delivery of the goods the Purchaser acknowledges that he is in possession of the goods solely as bailee for JMV Robotique as shall as bailee insure and keep the same insured in the name of JMV Robotique in their full reinstatement value in some reputable insurance office and indemnify JMV Robotique for any uninsured loss thereof. For the purpose of recovering the goods JMV Robotique may enter any premises where the goods are stored or where they are reasonably thought to be stored and may repossess the same. Until such time as the purchaser becomes the owner of the goods he will store them on his premises in a manner, which makes them readily identifiable as the goods of JMV Robotique. The Purchaser is licensed by JMV Robotique to agree to sell JMV Robotique' goods subject to the express conditions that the entire proceeds thereof are held in trust for JMV Robotique and are not mingled with other monies or paid into any overdrawn Bank Account and shall be at all times identifiable as JMV Robotique monies. The Purchaser is licensed to use the goods in the manufacture of other goods provided that if the goods being the property of JMV Robotique are mixed with goods being the property of the Purchaser or are processed with or incorporated therein the product shall be deemed to be the sole and exclusive property of JMV Robotique.

If the goods being the property of JMV Robotique are mixed with goods being the property of any person other than the Purchaser or incorporated therein the product thereof shall become or shall be deemed to be owned in common with that other person in proportion to the value of the constituent parts therein. The Purchaser is licensed by JMV Robotique to agree to sell on the said product subject to the express condition hereinbefore mentioned in relation to the proceeds of sale thereof.

10. SPECIFICATION

All drawings, specifications and particulars of the goods submitted are approximate only. The descriptions and illustrations contained in catalogues, price lists and other advertising of JMV Robotique are intended merely to present a general idea of the goods described therein and shall not form part of the Contract. Whilst every effort is made to ensure that the latest specification is available JMV Robotique reserves the right to incorporate new features and to supply products which may not be strictly in accordance with the specification agreed upon, provided that any changes in specification shall not materially prejudice the performance of the goods.

11. FORCE MAJEURE

JMV Robotique shall not be liable for failure to perform or delay in performance of any contract or for the loss or damage to goods directly or indirectly caused by force majeure to include acts of God, fire, theft, riot, war, embargo, strike, shortage of labour, delays in delivery of material by suppliers, prohibition or export or import, confiscation or any other occurrence (whether or not of a similar nature to those specified) beyond the control of JMV Robotique. No consequences of any such event shall give rise to the recession of the Contract unless in the opinion of JMV Robotique the contract becomes incapable of performance.

12. WARRANTY

- a) JMV Robotique warrants that the goods will be of good quality and that JMV Robotique has title to sell the same. JMV Robotique' warranty of workmanship (if provided) shall be effective from the date on which the goods were accepted in accordance with Clause 8 and limited to 12 months from dispatch or such period as may be notified ("the warranty period"). During the warranty period JMV Robotique will replace, free of charge, any part or parts of the goods which fail to function as a result of faults caused during their manufacture providing always that such faulty goods are returned carriage paid to JMV Robotique' premises. The goods when repaired by JMV Robotique will then be returned carriage paid to the Purchaser. JMV Robotique shall not be liable under this warranty:
- i) where the defect results from the goods being subjected to abnormal usage or where the defect is due to the act, neglect or default of anyone other than JMV Robotique
 - ii) for the replacement or repair of the goods or part or parts thereof where such replacement, or repair becomes impossible as a result of force majeure or any other circumstances beyond JMV Robotique' control
 - iii) where the goods or any components or parts thereof are the subject of a separate guarantee given by a third party.
 - iv) where failure is caused by abuse or neglect.
- b) The Purchaser acknowledges that if he has not notified to JMV Robotique any particular purpose for which the goods are required all express or implied warranties or conditions statutory or otherwise as to quality of or fitness for any particular purpose of the goods are hereby expressly excluded and JMV Robotique shall not (except as set out above) be under any liability whatsoever in respect of defects in goods delivered or for any injury, damage or loss resulting from such defects from any cause whatsoever.

13. LEGAL CONSTRUCTION

except where otherwise stipulated in writing the relations, arrangements and agreements between the parties shall be governed by the laws of England and all disputes which may arise under out of or in connection with any contract between JMV Robotique and the Purchaser shall be submitted to arbitration by the London Court of Arbitration in accordance with its Rules for the time being in force. Service of any notices in the course of such arbitration to the address of the Purchaser given in the Contract shall be valid and sufficient. All references in the Terms and Conditions to the masculine gender shall be deemed to include the feminine and neuter genders. Failure or neglect by JMV Robotique to enforce at any time any of the provisions hereof shall not be construed a waiver of JMV Robotique' rights nor in any way affect the validity of the whole or part of this contract nor prejudice JMV Robotique' rights to take subsequent action. The headings of the Terms and Conditions are inserted for convenience or reference only and are not intended to be part of or to affect the meaning or interpretation of any of the terms and conditions of this Contract. In the event that any of these terms, conditions or provisions shall be determined invalid, unlawful or unenforceable it shall be severed from the remaining terms, conditions and provisions that shall continue to be valid to the fullest extent permitted by law.

14. STERLING PROTECTION

any quoted or listed sterling prices are subject to variation in the rate of exchange between sterling and the currency paid by JMV Robotique for whole or major components between the date of the contract and the time of the submission of JMV Robotique' invoice to the Purchaser. JMV Robotique reserves the right to vary the price so that it accords with the said rate of exchange prevailing at the time of JMV Robotique' invoice.

15. DEFAULT

If the Purchaser shall default in the performance of any of its obligations under the Contract JMV Robotique shall on giving the Purchaser notice in writing have the right without prejudice to any other rights or remedies to take all or any of the following actions:

- a) cancel all or any part of any discount which might otherwise have been due under the terms of the contract;
- b) suspend any outstanding delivery of goods or parts thereof until such default shall have been made good;
- c) recover possession of that part of the goods to which the default relates and the Purchaser shall allow JMV Robotique free access to his premises to enable JMV Robotique to do so.

No waiver or delay in exercise by JMV Robotique of its right under this clause shall be deemed to imply acceptance of the default or any subsequent default. If the Purchaser shall become bankrupt, go into liquidation, have a Receiving Order made against him, or carry on his business under a Receiver JMV Robotique shall have the liberty without prejudice to any further remedies under the Contract to terminate the Contract forthwith by notice in writing to the Purchaser or Liquidator and recover possession of all equipment for which full payment of the contract price has not been received in c. above.

Supplied by:

JMV ROBOTIQUE

ZI du Clos Aux Pois
6/8 Rue de la Closerie
LISSES
91048 EVRY Cedex
France

Tel: 33 (0) 1 60 86 15 25

Fax: 33 (0) 1 60 86 10 74

Email: contact@jmvrobotique.com

Website: www.jmvrobotique.com